

Kriss³ 8,5 kW

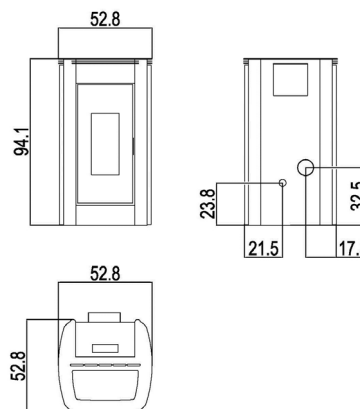

ACIER

- BLANC
7015036
EAN 8033123616614
- ROUGE
7015033
EAN 8033123616584
- ANTHRACITE
7015035
EAN 8033123616607
- LIGHT BRONZE
7015034
EAN 8033123616591



EXTRA



Chambre étanche



Poignée main froide



Télécommande



Liaison thermostat externe



Protection anti surchauffe



Braser en fonte



Programmation journalière hebdomadaire



Sortie fumée postérieure

DONNÉES TECHNIQUES

Puissance nominale	kW	8,5
Puissance réduite	kW	2,3
Puissance utile à l'eau nominale	kW	-
Puissance utile à l'eau réduite	kW	-
Rendement nominal	%	90
Rendement réduit	%	93
Capacité de chauffe (min-max)	m ³	50 - 204
CO à 13% O ₂ nominal	%	0,009
CO à 13% O ₂ réduit	%	0,051
Contenu de poussières à 13% O ₂ nominal	mg/Nm ³	8
Capacité chaudière (H ₂ O)	l	-
Capacité réservoir	kg	18
Combustible		Pellet ø6
Consommation horaire (min-max)	kg/h	0,50 - 2,00
Autonomie (min-max)	h	36,0 - 9,0
Absorption électrique d'allumage (max)	W	360
Absorption électrique de travail (max)	W	60
Tension d'alimentation et fréquence	V - Hz	230 - 50
Dépression cheminée	Pa	12
Diamètre sortie fumées	mm	80
Diamètre prise d'air comburant	mm	40
Masse des fumées (min-max)	g/sec	3,2 - 4,5
Température des fumées en sortie (max)	°C	198
Poids net	kg	80
Poids brut	kg	90

EMBALLAGE ET STOCKAGE

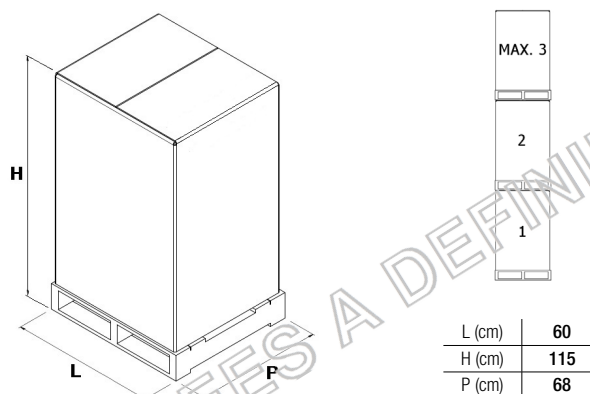

EMBALLAGE FINITIONS

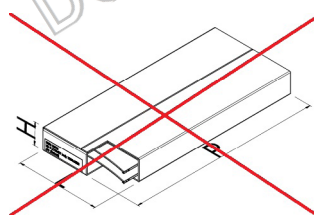

FINITION	L (cm)	H (cm)	P (cm)



EN 14785:2006



BImSchV 2015



Regensburg



München



Stuttgart



Aachen